

CT-8000 S3

digital circuit breaker analyzer



Vanguard Instruments
A DOBLE COMPANY





CT-8000 S3

digital circuit breaker analyzer

Product Overview

The CT-8000 S3 is Vanguard's fourth generation EHV circuit breaker analyzer. The CT-8000 S3 is available with 3 or 6 contact timing channels (part number 9103-UC and 9104-UC, respectively). The CT-8000 S3 can fully analyze a circuit breaker's performance by measuring the main contact and resistor contact time, stroke, velocity, over-travel, bounce back and contact wipes. Also, an outstanding feature of the CT-8000 S3 is the ability to perform dynamic resistance tests on circuit breaker contacts.

ordering information

Part No.	Description
9103-UC	CT-8000 S3 with 3 contact channels, cables, and PC software
9104-UC	CT-8000 S3 with 6 contact channels, cables, and PC software
9103-DG	Dual ground option
9103-OT	On-line timing option
9103-BT	Bluetooth option
9103-SC	CT-8000 S3 shipping case
TP4-CS	TP4 thermal printer paper (24 rolls)

Dynamic Contact Resistance

The CT-8000 S3 can perform dynamic-resistance tests using a 200-ampere, built-in, DC power supply. One channel is available for performing a dynamic contact resistance test. The resistance measuring range is from 1 micro-ohm to 1,999 micro-ohms. The resistance chart can be used to analyze the circuit-breaker contact condition during the CB operation. This important feature can help detect circuit-breaker contact erosion or other contact problems that cannot be detected in static resistance tests. The CT-8000 S3 can also be used as a 200-ampere micro-ohmmeter to test circuit-breaker contact resistance and bus connections, or can be used for other applications where a low-resistance measurement is required.

Contact Timing Input Channels

The CT-8000 S3's dry contact timing channels (up to 6 channels) are used to time the circuit breaker main contacts. Each main contact timing channel is capable of detecting the main contact and insertion resistor contact time. Timing results are displayed in milliseconds and cycles. The CT-8000 S3's timing window is selectable between 1 second, 10 seconds, and 20 seconds.

Resistor Type Transducer Inputs

The CT-8000 S3 offers 3 resistor type transducer input channels. These input channels are used to interface with any resistor-type transducers to monitor the circuit breaker motion. Transducer resistance ranges from 200 Ohms to 10K Ohms.

Breaker Stroke and Velocity

Three dedicated digital travel transducer channels are available on the CT-8000 S3 for measuring circuit-breaker contact stroke, velocity, over-travel, and bounce back. With the use of the Vanguard digital travel transducers, neither calibration nor setting is required. Circuit breaker contact velocity is calculated based on contact's travel distance over a period of time. Special formulas to calculate velocity is also accommodated by the CT-8000 S3. Special feature is also available to "Slow-Close" test the circuit breaker and obtain a test result report.

Voltage Monitoring Channels

The CT-8000 S3 features three voltage monitoring input channels (V1, V2, and V3). The V1 voltage channel is dedicated to monitoring the substation DC supply or coil voltage (0-255 V, DC or peak AC). The nominal and minimum DC supply voltage levels are recorded and printed on the tabulated report. An analog waveform showing the DC power supply is plotted on the graphical report. The two digital voltage input channels, V2 and V3, are dedicated to monitoring voltage on/off status presence or absence of the circuit breaker auxiliary switches. Digital waveforms showing V2 and V3 activity are plotted on the graphical report. Three timing events of the V2 and V3 activities are recorded and printed on the tabulated report.

Breaker Initiate Features

A built-in solid-state initiate device is used to operate a breaker from the CT-8000 S3. Operational modes include OPEN, CLOSE, OPEN-CLOSE, CLOSE-OPEN, and OPEN-CLOSE-OPEN. Multiple operation like OPEN-CLOSE, CLOSE-OPEN, and OPEN-CLOSE-OPEN can be initiated by using a programmable delay time (in milliseconds) or by sensing a specific breaker contact condition.

OPEN/CLOSE Coil Current Monitoring

One built-in, hall-effect sensor records the OPEN/CLOSE coil current amplitude and waveform. The circuit breaker's coil current waveform, effectively, a coil performance "fingerprint" or "current profile", can be used as a diagnostic tool for analyzing the circuit breaker's performance.

Computer Interface

The CT-8000 S3 can be computer-controlled via the USB or optional Bluetooth interface. Windows-based Circuit Breaker Analysis Software is provided with each unit. Using this software, circuit breakers can be timed from the PC. Test records can be retrieved from the CT-8000 S3 and then stored on the PC for future analysis and report generation. Circuit breaker test plans can also be created on the PC and transferred to the CT-8000 S3. Additionally, test records can be automatically exported in Excel, PDF, and XML formats.

CT-8000 S3 Features

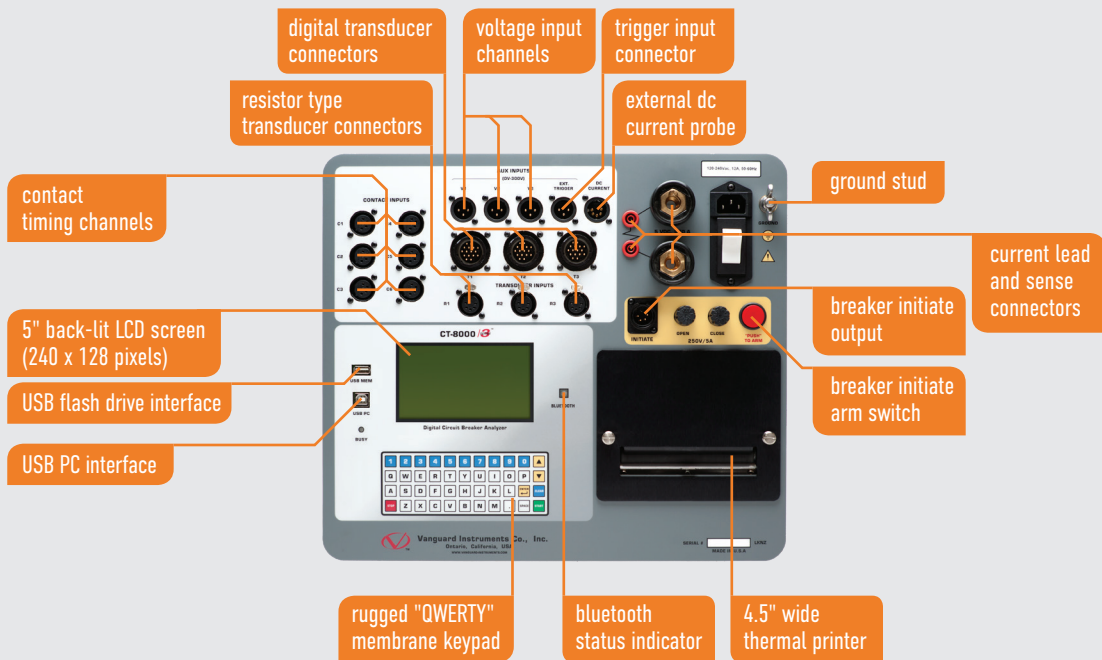

Built-in Thermal Printer

The CT-8000 S3's built-in 4.5" wide thermal printer can print the breaker contact analysis results in both tabular and graphic formats.

User Interface

The CT-8000 S3 features a back-lit graphic LCD screen (240 x 128 pixels) that is viewable in direct sunlight and low-light levels. A rugged 44-key "QWERTY"-style membrane keypad is used to control the unit and input information.

Internal Test Record and Test Plan Storage

The CT-8000 S3 uses Flash memory to store up to 200 test records internally. Test records can be recalled and printed on the unit's built-in 4.5" wide thermal printer. Test records can also be transferred to a USB Flash drive or exported to a PC via the USB port or Bluetooth (optional) with the included Windows-based software.

Up to 100 circuit breaker test plans can be stored in the CT-8000 S3's Flash memory. A test plan is comprised of all circuit breaker performance specifications (contact time, stroke, velocity, etc.). When a test plan is used with a timing test, a Pass/Fail report is generated by comparing the actual performance with the specifications in the stored test plan. Test plans can be transferred to the CT-8000 S3 from a USB Flash drive, or from a PC via the USB port or Bluetooth (optional).

Diagnostic Capabilities

The CT-8000 S3 can perform diagnostics on its internal electronics. Diagnostics can be performed to verify contact cable connections and to test the travel transducer's electronics.

Optional Features

"On-line" Timing Mode



In addition to the conventional off-line timing mode, the CT-8000 S3 also offers an optional three-phase "on-line" timing mode. In this mode, the CT-8000 S3 captures the breaker's trip or close time, the trip/close coil current "fingerprint," and the battery supply voltage while the breaker is still in service. The trip/close time is derived from the time of trip, or close coil initiation, to the breaker's bushing current breaker-make as detected by a AC clamp-on current sensing probes. Trip/Close current waveforms

are also captured by an external clamp-on DC current probe.

The "on-line" timing mode can detect a breaker's operating conditions with little or no down time. In this mode, the first trip operation time of the breaker is captured. If a breaker has been in service for a long period of time and sitting in close position, the first trip time of the breaker may be slow possibly due to a sticky mechanism. The "on-line" mode is very useful in such cases because traditional breaker timing may not detect this condition since several operations may have occurred before the first timing test is conducted.



Dual Ground Testing Mode

With the optional dual ground testing mode, the CT-8000 S3 can measure a CB contact time with ground being applied to both sides of the bushings. The clamp-on probe is connected to one side of the CB safety ground straps, and an AC signal is coupled to this strap. A sensor on the probe will detect a change in the induced AC signal when the CB contact is opened or closed.

Bluetooth Interface

The optional Bluetooth interface can be used to wirelessly connect the CT-8000 S3 with a PC.

CT-8000 S3 Connections

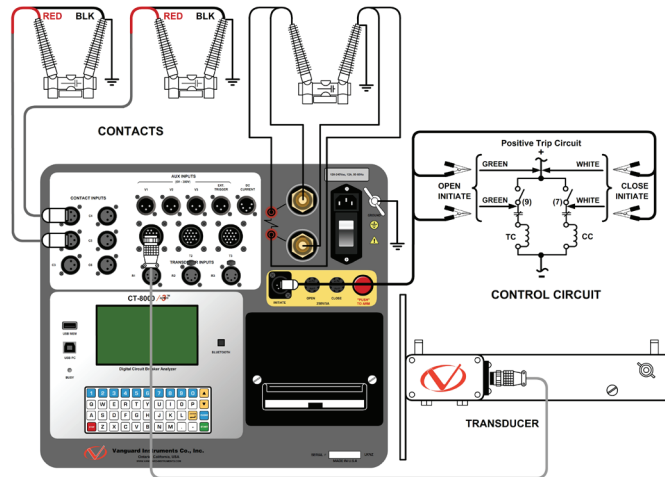

Typical CT-8000 S3 Dynamic Resistance Test Connections

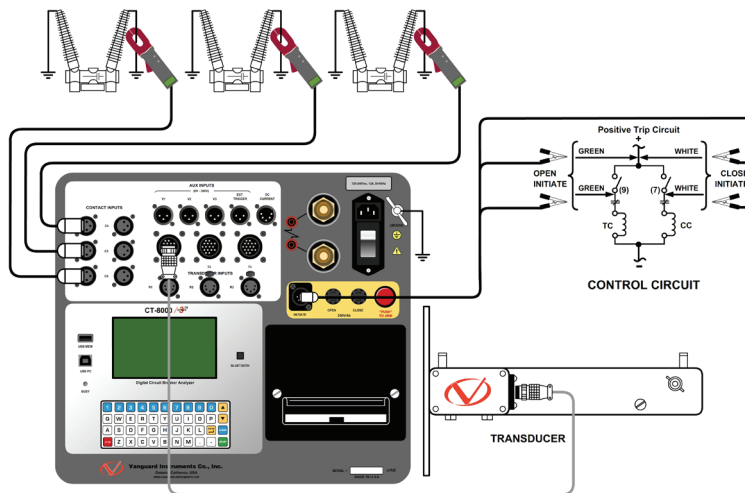



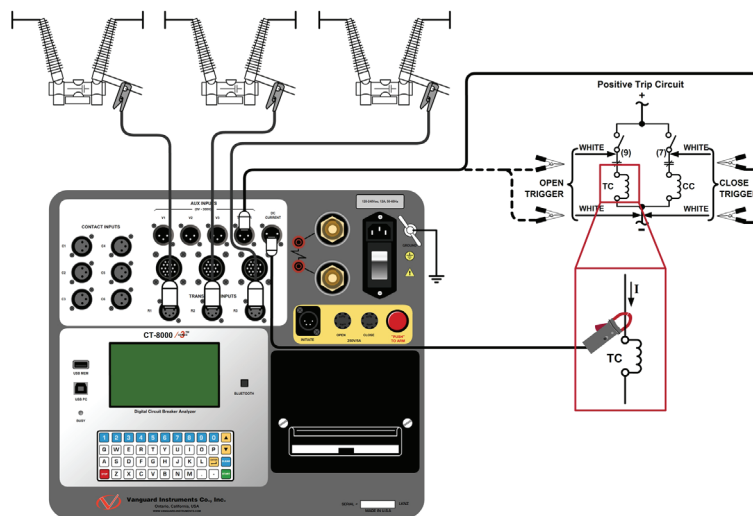

























Connections for Optional Dual Ground Testing Mode



Connections for Optional Online Timing Mode

CT-8000 S3 technical specifications

 physical specifications	Dimensions: 16"W x 11"H x 14"D (40.6 cm x 29.9 cm x 35.6 cm) Weight: 22 lbs. (9.98 Kg)	 input power	10 A, 100 – 240 Vac, 50/60 Hz
 dry-contact inputs	3 channels (9103-UC) or 6 channels (9104-UC). Each channel can detect the main contact and resistor contact time.	 timing windows	1 second, 10 seconds, or 20 seconds
 timing resolutions	±50 micro-seconds @ 1 sec. duration, ±500 micro-seconds @ 10 sec. duration, ±1.0 milliseconds @ 20 sec. duration		
 timing accuracy	0.05% of reading ±0.05 milli-seconds @ 1 second duration	 dry-contact detection range	closed: less than 20 ohms; open: greater than 5,000 ohms
 resistor detection range	50 – 5,000 ohms	 trigger input voltage	open/close: 24 – 300 V, dc or peak ac
 dry contact input protection	All contact inputs are grounded until test. Input channels are also protected against static discharge.	 breaker operations	initiate open, close, open-close, close-open, open-close-open
 voltage sensing input range	V1: analog input; 0 – 250 V dc or peak ac; sensitivity ±1 V; record and print voltage level V2 and V3: voltage presence/absence detector input; 24 – 255 V dc or peak ac; record and print 3 timing events		
 breaker initiate capacity	30 A, 250 V ac/dc max	 resistor type transducer inputs	3 channels, 200 ohms – 10 K ohms
 digital travel transducer input	3 digital travel transducer channels; linear range: 0.0 – 60.0 in (±0.01 in); rotary range: 0 – 360 degrees (±0.36 degrees)		
 initiate current reading range	one, non-contact, Hall-effect sensor, 0 – 20 amp range, dc to 5 KHz ac	 contact travel point difference	measures "slow-close" contact-point distances; results can be printed
 dynamic/static resistance range	0.1 – 1,999 micro-ohms; accuracy: ±2% of reading, ±5 micro-ohms	 resistance test current	200 A max
 display	5" back-lit LCD screen (240 x 128 pixels); viewable in bright sunlight and low light levels	 internal test record storage	stores up to 200 test records and 100 test plans
 printer	built-in 4½" wide thermal printer that can print both graphic contact travel waveforms and tabulated test results	 external data storage	USB Flash drive interface for external storage of test records and test plans
 pc software	Windows®-based Circuit Breaker Analysis software (VCBA S2) included with purchase price. Software updates available at no additional charge		
 safety	designed to meet UL 6101A-1 and CAN/CSA C22.2 No 1010.1-92 standards		
 temperature	Operating: -10°C to +50°C (+15°F to +122°F) Storage: -30°C to +70°C (-22°F to +158°F)		
 cables	20' (6.1 m) contact leads, 30' (9.1 m) contact lead extensions, 20' (6.1 m) control and voltage cables, 25' (7.6 m) digital transducer cable, USB cable, power cord, ground cable		
 options	shipping cases (available for the CT-8000 S3 and travel transducers), on-line timing mode, dual ground testing mode, bluetooth interface	 warranty	one year on parts and labor

NOTE : the above specifications are valid at nominal voltage and ambient temperature of +25°C (+77°F). Specifications are subject to change without notice.

Optional Testing Features

on-line timing mode

on-line current sensor three non-contact ac current sensors, range 0 – 100 A

on-line dc current sensor one non-contact dc current sensor, range 0 – 20 A

on-line timing accuracy ±1 ms

dual ground timing mode

dual ground clamp-on probes three non-contact ac current sensors, range 0 – 100 A

dual ground timing accuracy ±1 ms

CT-8000 S3 Desktop Printer output

Desktop printout of tabulated test results

Vanguard Instruments Company, Inc.

Filename: 76072-052908-SHOT069.DAT Date/Time: 01/30/15 11:36:25
 Company: DUKE ENERGY Manufacturer: SIEMENS
 Station: DAN RIVER 100 YARD S/N: 30075423 4
 Circuit: 30075423 4 Operator: J THOMPSON
 Model: SPS2 Test: OPEN

CONTACT (OPEN)

CHA	P/F	Time(ms)	Cycle	Bounce(ms)	Wipe(mm)
1	P	27.300	1.64	0.05	34.04
2	P	27.500	1.65	0.05	34.93
3	P	27.200	1.63	-0.05	33.53

Delta Time(ms): 0.300 (P/F) = F

CT Channel Analysis: 0.000 (ms)

Travel Analysis

	T1	P/F
Stroke (mm)	109.22	P
Velocity (m/s)	5.49	P
Overtravel (mm)	4.19	P
Bounce Back (mm)	2.16	P

Speed Analysis

AP1 CT

AP2 CT+10.000 ms

Initiator Current: 12.136 A V1 Nominal: 0V V1 Min: 0V

Shot Length: 1 SEC

Insertion Resistor: None

Delay: None

Trigger: Internal

Desktop printout of graphic test results



CT-8000 S3 Thermal Printer Output

Thermal printout of tabulated test results

BREAKER TIMING RESULTS - 60 Hz				
SHOT NUMBER: 44				
DATE: 01/17/15 TIME: 14:41:02				
COMPANY: VANGUARD INSTRUMENTS				
STATION: STATION NUMBER 1				
CIRCUIT:				
MFR: ABB				
MODEL: 72PM31 12B				
S/N: 101797				
OPERATOR:				
TEST: OPEN				
CONTACT TIME				
CH	TIME	CYCLE	BOUNCE	WIFE
	<ms>		<ms>	<ms>
1	39.35	1.98	0.05	47.80
2	39.15	1.99	0.15	47.80
3	39.50	2.01	0.10	47.9
DELTA TIME <ms>: 0.35				
TRAVEL ANALYSIS:				
			T1	
STROKE	mm	120.1		
SPEED	M/S	0.21		
OVER-TRAVEL	mm	1.1		
BOUNCE BACK	mm	0.6		
SPEED ANALYSIS:				
POINT 1	=	30.0 mm		
POINT 2	=	70.1 mm		
U1 NOMINAL VOLTAGE = 0 VOLTS				
U1 MINIMUM VOLTAGE = 0 VOLTS				
U2/U3 TRANSITION TIMES				
	U2	U3		
T1:	35.50 ms	35.90 ms		
T2:	N/A	N/A		
T3:	N/A	N/A		
INITIATOR CURRENT = 9.7 AMPS				
SHOT LENGTH: 1 SECOND				
INSERTION RESISTOR: NO				
TRIGGER: INTERNAL				

Thermal printout of graphic test results

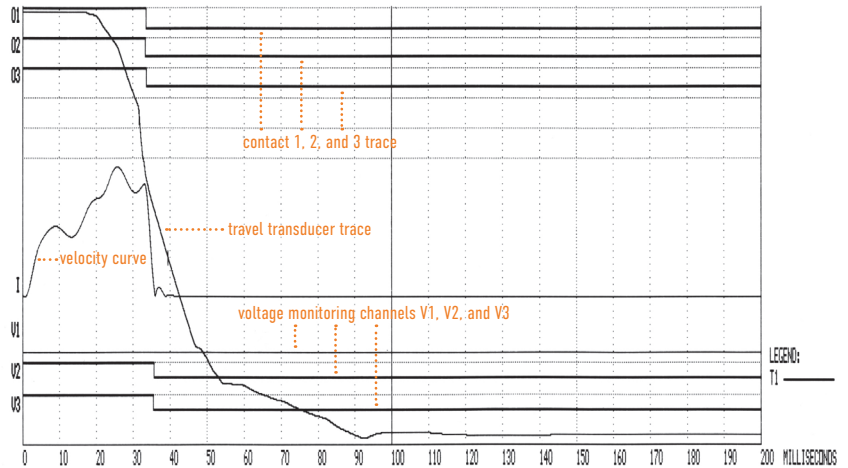

Thermal printout of dynamic resistance test graph

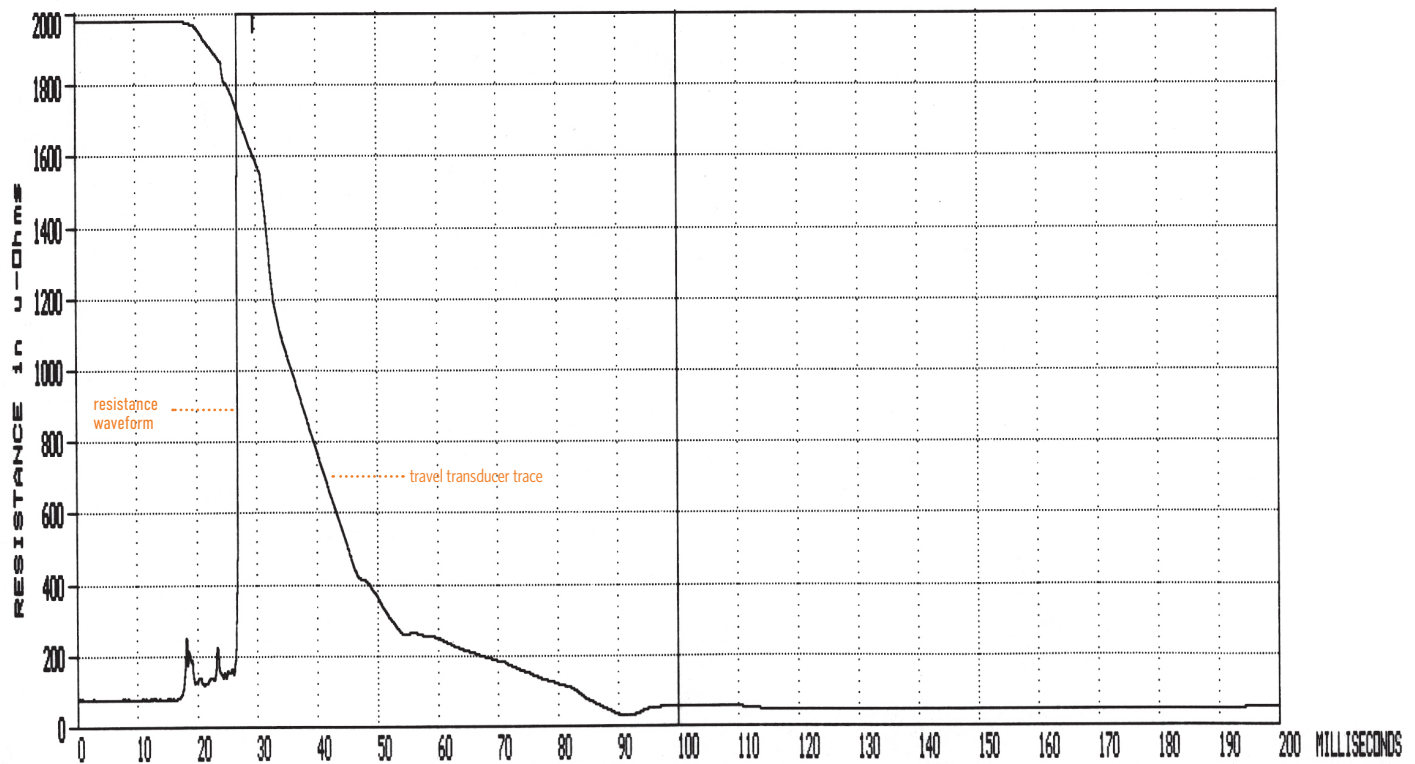



Instruments designed and developed by the hearts and minds of utility electricians around the world.

Founded in 1991 and located in Ontario, California, USA, Vanguard Instruments™ offers a wide range of diagnostic test equipment that accurately and efficiently measures the health of critical substation equipment, such as transformers, circuit breakers, and protective relays.

Our first product was a computerized, extra high voltage (EHV) circuit breaker analyzer, which became the forerunner of an entire line of EHV circuit breaker test equipment. Over the years, our portfolio has grown tremendously to include microcomputer-based precision micro-ohmmeters; single- and three-phase transformer winding turns-ratio testers; transformer winding-resistance meters; mega-ohm resistance meters; and a variety of other application-specific products.

Our instruments are rugged, reliable, accurate, and user friendly. They eliminate tedious and time-consuming operations, while providing fast, complex test-result calculations. Using our equipment helps reduce errors and eliminates the need to memorize long sequences of procedural steps.

In 2017, Vanguard Instruments became a part of Doble Engineering Company, an energy industry leader in hardware, software, and services that diagnose and monitor the health of critical assets.



Vanguard Instruments

A DOBLE COMPANY

1520 S. Hellman Avenue
Ontario, California 91761, USA
Phone 909-923-9390 • Fax 909-923-9391

www.vanguard-instruments.com

Revision C. March 16, 2018

© Copyright 2018 Doble Engineering Company

